



VR60 GLASS FROSTERS

INSTALLATION AND OPERATING MANUAL

PLEASE LEAVE WITH OPERATOR



VR60 Glass Froster

Series 4

Imperial Machine Company Limited
Unit 1, Abbey Road
Wrexham Industrial Estate
Wrexham LL13 9RF
Tel: +44 (0)1978 661155
Fax: +44 (0)1978 729990
Service Fax: +44 (0)1978 667766
Spares Fax: +44 (0)1978 667759
E-mail: info@imco.co.uk
Website: www.imco.co.uk

A34/055 R5

ECN 8917 January 2020

EC DECLARATION OF CONFORMITY

(Guarantee of Production Quality)

We, Imperial Machine Company Limited of:

Unit 1, Abbey Road, Wrexham Industrial Estate, Wrexham, LL13 9RF

Declare under our sole responsibility that the following products

VR60

as described in the attached technical documentation, are in conformity with the protection requirements of the Electromagnetic Compatibility Directive 2014/30/EU and manufactured in accordance with harmonised standards EN 61000-6-1: 2001 Immunity and EN 61000-6-3: 2007 Emissions (plus product specific standards).

They also satisfy the essential health and safety requirements of the Low Voltage Directive 2014/95/EC and are manufactured in accordance with standards BS EN 60335-1 and BS EN 60335-24, and the relevant requirements of the Pressure Equipment Directive 2014/68/EU.

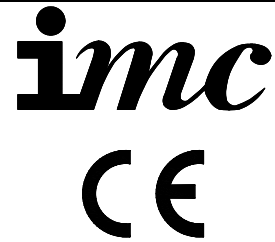

Approved by : E.Plumb, Engineering Manager -

A handwritten signature in black ink, appearing to read 'E. Plumb', written over a horizontal line.

Date: January 2020

INDEX

INDEX	3
WARRANTY	4
DELIVERY	4
SAMPLE RATING LABEL.....	5
INTRODUCTION.....	5
INSTALLATION	7
CHANGING AN LED LIGHT FITTING.....	8
CHANGING OPTION DOOR HANDLES	9
ELECTRICITY SUPPLY CONNECTION.....	10
COMMISSIONING	10
CHANGING THE CONTROLLER SET POINT	11
USING YOUR GLASS FROSTER	11
ECO BUTTON FUNCTION	12
CLEANING.....	13
CHANGING SHELF POSITION	13
MAINTENANCE	14
DO'S AND DON'TS	15
ORDERING SPARE PARTS.....	16
END OF LIFE DISPOSAL.....	16
MATERIAL CONTENT.....	16
WIRING DIAGRAM	17
SPARES LIST DRAWING 1	18
SPARES LIST DRAWING 2	19
SPARES LIST	20
NOTES.....	21

WARRANTY

These Glass Frosters are guaranteed by IMC for 2 years from the date of purchase from IMC, or from one of its stockists, dealers or distributors. The guarantee is limited to the replacement of faulty parts or products and excludes any consequential loss or expense incurred by the purchaser. Defects which arise from faulty installation, inadequate maintenance, incorrect use, connection to the wrong electricity supply, or fair wear and tear, are not covered by the guarantee.

The guarantee applies in this form to installations within the United Kingdom. Export units carry 2 years parts only warranty.

Please observe these instructions carefully.

DELIVERY

The packaged machine consists of:

VR60 Glass Froster containing:	
Shelf (Full size)	2
Shelf (base ½ size)	1
Shelf clips	8
Sets of keys	2
Instruction Booklet	1

Please notify both the carrier and the supplier **within three days** of receipt if anything is missing or damaged.

Check that the correct machine has been supplied and that the voltage, marked on the rating plate, is suitable for the supply available. The rating plate is located internally on the right hand side of the unit.

SAMPLE RATING LABEL

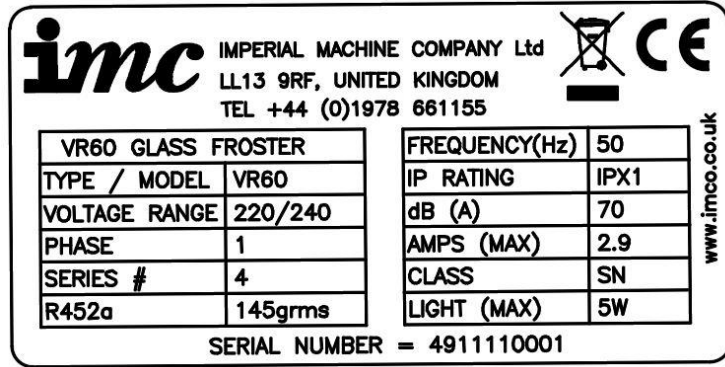

INTRODUCTION

The VR60 range is a back-bar or under-bar glass froster designed for the frosting and storage of glasses.

The following quantity of standard pint glasses can be held in each unit:

Glass Froster	Capacity (Standard Pint Size Glass)
VR60 (900h x 600w x 500d)	50
VR60 (800h x 600w x 500d)	50

VR60 Dimensions:

<u>MODEL</u>	<u>X</u>	<u>Y</u>
VR60 900mm	500	900
VR60 800mm	500	800

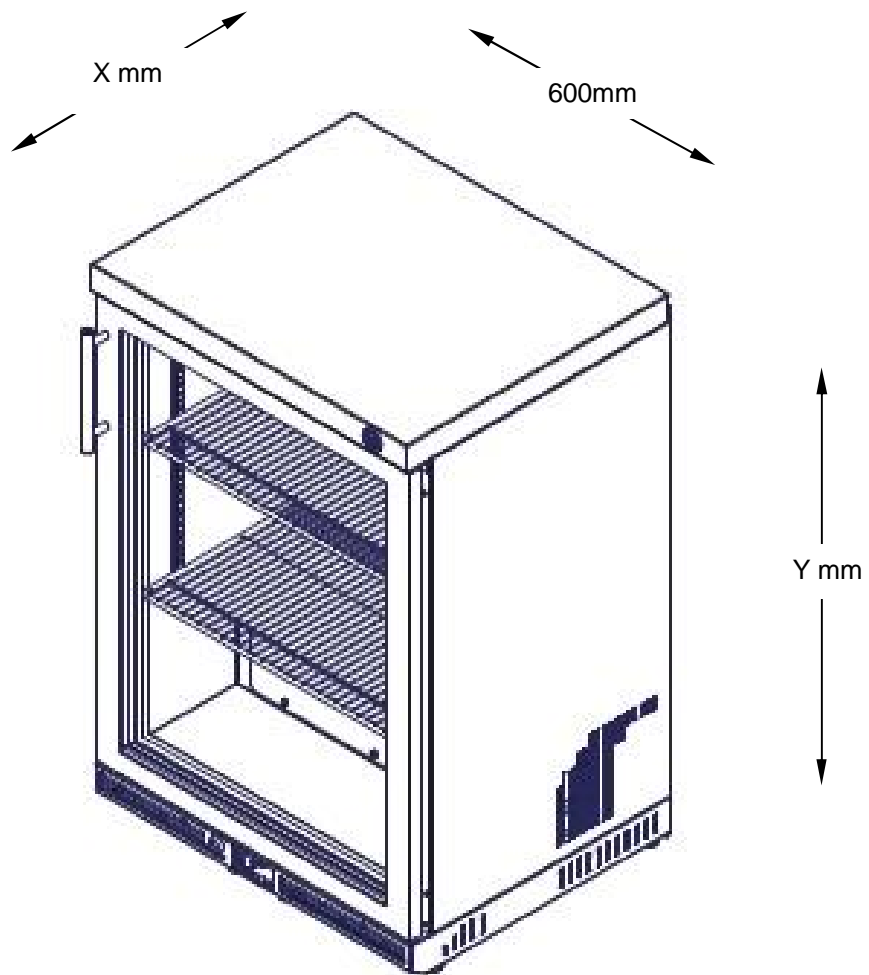

VR60

INSTALLATION

For the Installer

These Instructions contain important information designed to help the user obtain the maximum benefit from their investment in an IMC VR60 Glass Froster.

Please read them carefully before starting work, and consult with the supplier in the event of any queries.

Be sure to leave this Instruction Manual with the user after installation of the machine is complete.

Procedure



WARNING

The following table shows the weight and the minimum quantity of people required to lift each unit:

Glass Froster	Net Weight	Quantity of People
VR60 (all variants)	57.5 kg (max)	2

Install the unit on a flat and level floor.

Ensure a minimum 10mm clearance to either side of the unit, there is to be a 20mm clearance at the top and 60mm clearance at the back.

Do not install the unit close to a heat source such as a radiator or a warm air outlet.

Ensure that the unit is standing level by adjusting the feet on the base of the unit.

The unit has an automatic defrost cycle and evaporates all the condensate water without the need for a drainage system.

NOTE!

It is important to install the Glass Froster on a flat surface. This ensures that the doors are level. Adjustment is provided via the feet, to enable the installer to level the cabinet. Engineer Call-outs in order to level Glass Frosters, will not be covered under warranty.

CHANGING AN LED LIGHT FITTING

The cabinet interior is illuminated by a LED light strip fitting located at the front of the top inner panel.

To change the light assembly:

- Ensure the mains power to the unit has been turned off.
- Open the front cabinet door(s).
- Unscrew the screws holding the LED assembly in place.
- Carefully lower the LED assembly down and disconnect the 2 wires from the unit.
- The LED light assembly should now be free to fully remove from the unit.
- To fit the replacement unit.
- Place the new LED light assembly inside the unit, re connect the 2 wires from the unit to the new LED light assembly.
- Re fit the LED light assembly inside the unit by using the screws.
- Re-connect the mains power and ensure the light illuminates by means of the ECO switch.

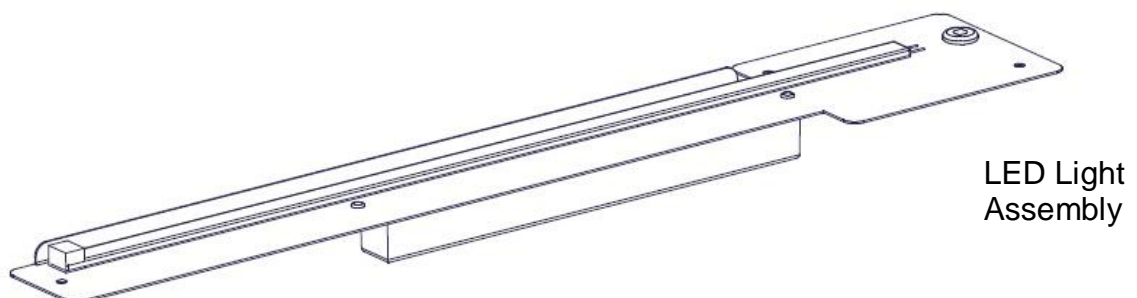
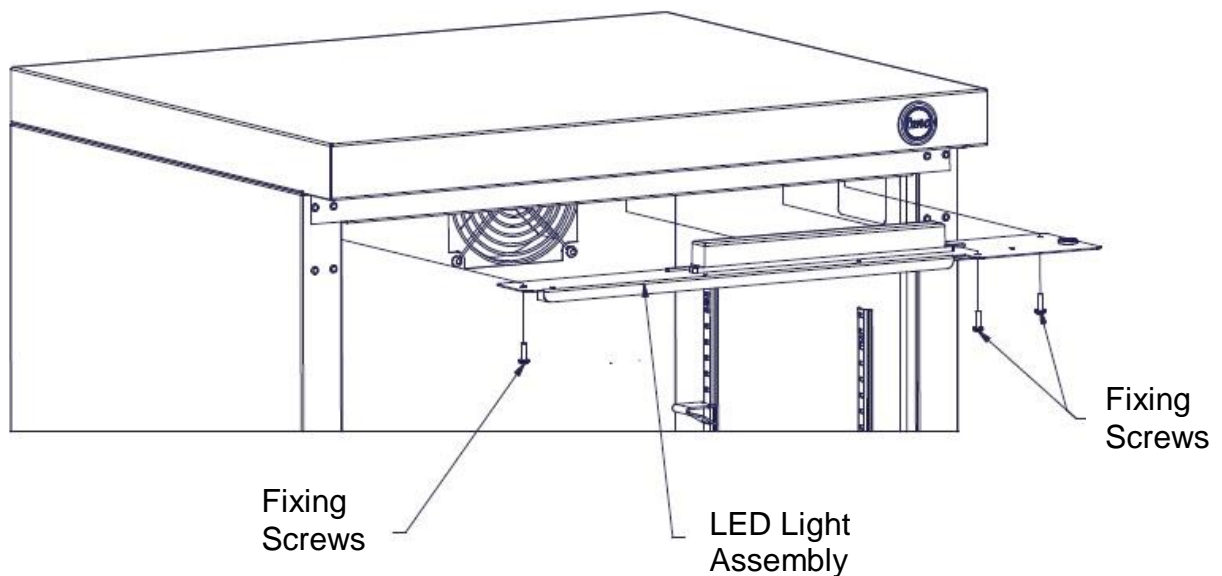

CHANGING OPTION DOOR HANDLES

The option doors have 2 types of handle which are removed and fitted in the same way. However, the long handle option has 4 screws and the short handle option has 2 screws.

To change or move a handle:

- Open the front cabinet door(s)
- Using a phillips screw driver, unscrew all the screws that secure the handle in place, then remove the handle and retain the screws
- Place new / same handle in desired position (see orientations below)
- Fix the handle back to the door with the same / supplied screws
- New / additional handles are available from IMC

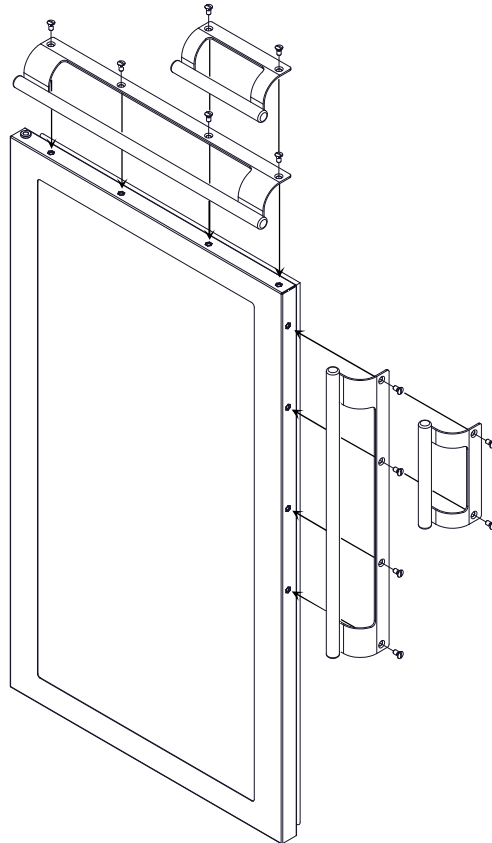

ELECTRICITY SUPPLY CONNECTION

Position the unit in the chosen site. The electricity supply connection should be made to a power outlet socket or isolator mounted on the wall close to the machine. This socket or isolator must be accessible once the machine is installed. Before connecting, check that the voltage shown on the rating label is correct for the electricity supply you have available. If the plug does not fit your sockets or a longer lead is required, changes must be made by an approved electrician.

NOTE: The plug is fitted with a 10amp fuse.

The plug fuse cover must be refitted when changing the fuse. In the event of losing the fuse cover the plug must NOT be used until a replacement fuse cover has been obtained and fitted or the plug replaced.

WARNING: This machine must be earthed

Should the supply cord become damaged then a replacement must be fitted by an approved electrician. The IEE Codes of Practice must be observed.



The wires in the mains lead are coloured in accordance with the following code

Green and yellow	Earth
Blue	Neutral
Brown	Live

COMMISSIONING

Before using a bottle cooler for the first time, the interior should be wiped out with a clean damp cloth.

Allow the machine to stand for 1 hour to allow the refrigerant to settle. Plug in and switch on at the wall socket. There is no separate switch to turn on the machine. The compressor will start running less than one minute after the supply is switched on.



Check that the CO+ button is not depressed i.e. the blue logo is illuminated. (See relevant section for the operation of this CO+function)

Check that the light is working. If a fluorescent light is fitted, the switch is located inside the cabinet, on the left hand end of the top inner panel.

Run the unit empty, and check that cold air is being circulated within the cabinet.

CHANGING THE CONTROLLER SET POINT

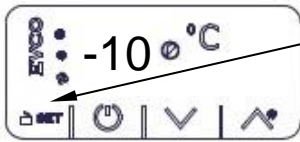
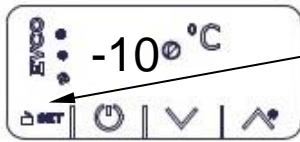
The electronic temperature controller is factory set to -10°C and will cycle the air temperature between -8°C and -12°C. The set point can be adjusted between -10°C and -15°C by following the button sequence below:

- 1)  Press SET the current SET Point will be displayed, if Loc is displayed then the controller is locked, to unlock press and hold the SET button for 3 seconds, UnL will then be displayed
- 2)  Press SET button and the current set point temperature will be displayed
- 3)  Use the UP and DOWN buttons, to scroll to the desired set point temperature (min -15°C, max -10°C)
- 4)  Press SET button to accept
Then press stand-by button to esc. Display will revert back to current internal air temperature

USING YOUR GLASS FROSTER

This unit is for Frosting Glasses only. Do not load the cabinet with boxed goods as this prevents air circulation and the goods will not cool down as quickly. While loading ensure that the interior grilles are not obstructed by the bottles.

Do not place hot or warm goods in the cabinet. Only goods at room temperature or less should be placed in the unit, otherwise performance will be affected. It is recommended that the cabinet is stocked after closing at night or first thing in the morning to allow time for the glasses to cool. Ensure that stock is rotated by placing new stock at the back of shelves or in one side of the cabinet to ensure that colder glasses are used first.

Do not leave the doors open when the unit is running as this causes the evaporator to ice up, preventing the unit from operating efficiently.

Ensure that the front grille is always unobstructed.

ECO BUTTON FUNCTION

This button (located in the right hand corner of the worktop) provides an energy saving when depressed i.e. blue logo is not illuminated.

This button switches off the internal light and raises the cabinet's current set point by 6°C (e.g. if current set point is -10°C it will be raised to -4°C) while in the depressed state (e.g. over night or during periods when the bar is closed). This will provide an energy saving to the customer providing the door(s) is (are) kept closed during this period. This saving can vary depending on the type and mix of stock within the cabinet, and also the length of time the cabinet is in this economy mode.

When the cabinet is placed in economy mode a green symbol in the bottom left hand corner of the controller flashes to indicate it is in ECO mode, and will stop flashing once the cabinet is returned to standard mode.

To return to standard operation the button must be released i.e. blue logo will be illuminated, and the internal light will illuminate. The set point of the cabinet will return to its original setting. (cooling the bottles/cans to normal serving temperature)

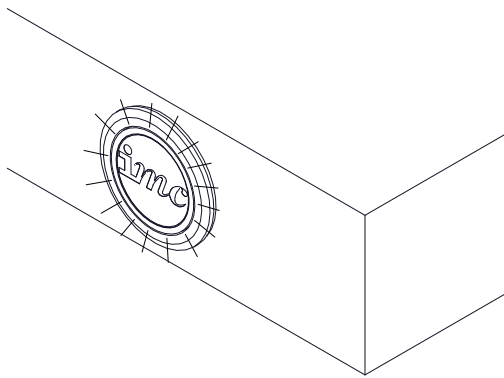

Standard mode: Button released,
logo & internal light illuminated

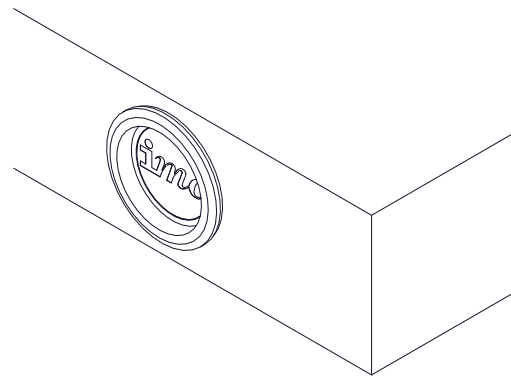

Eco mode: Button depressed,
logo & internal light off . (symbol
flashes on controller)

CLEANING

Clean doors and surfaces as required, occasionally remove all merchandise and clean interior surfaces with a clean damp cloth.

DO NOT USE CLEANING MATERIALS CONTAINING ABRASIVES OR BLEACHES.

In the case of heavy soiling use a mild liquid detergent. The unit can be washed on the inside using bicarbonate of soda to remove stale smells.

CHANGING SHELF POSITION

The shelves in all VR60 Glass Froster units are fully adjustable. To adjust the shelves:

- Remove the shelf.
- Unclip the shelf supports as shown below.

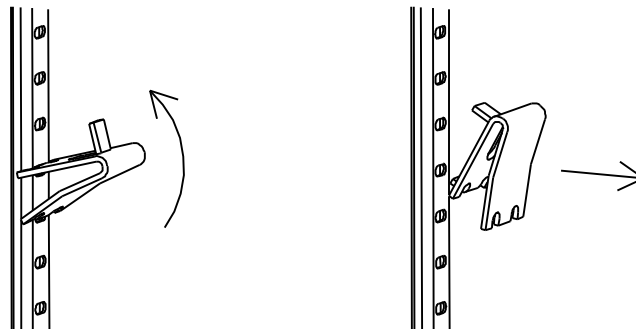

- Hook the shelf supports in the required location.
- Ensure all shelf supports are at the same height for a level shelf. The support strips are numbered to aid positioning.
- Replace the shelf.

Extra shelves are available from IMC.

MAINTENANCE



Warning

Never service, repair or troubleshoot a unit unless you are a professional air conditioning / refrigeration service person. Improper servicing can lead to serious injury or death from fire, electric shock or explosion.

Remove the service panel and insulation block inside the cabinet after switching the unit off from the mains supply. Clean the compressor coil with a brush and vacuum cleaner. THIS MUST BE DONE every three months or when dirty (whichever is sooner). Re-fit the insulation and service panel and secure with the original screws. Once the service panel has been re-fitted clean the grille at the bottom front of the cabinet. Re-connect the power supply and check that unit returns to normal operation.

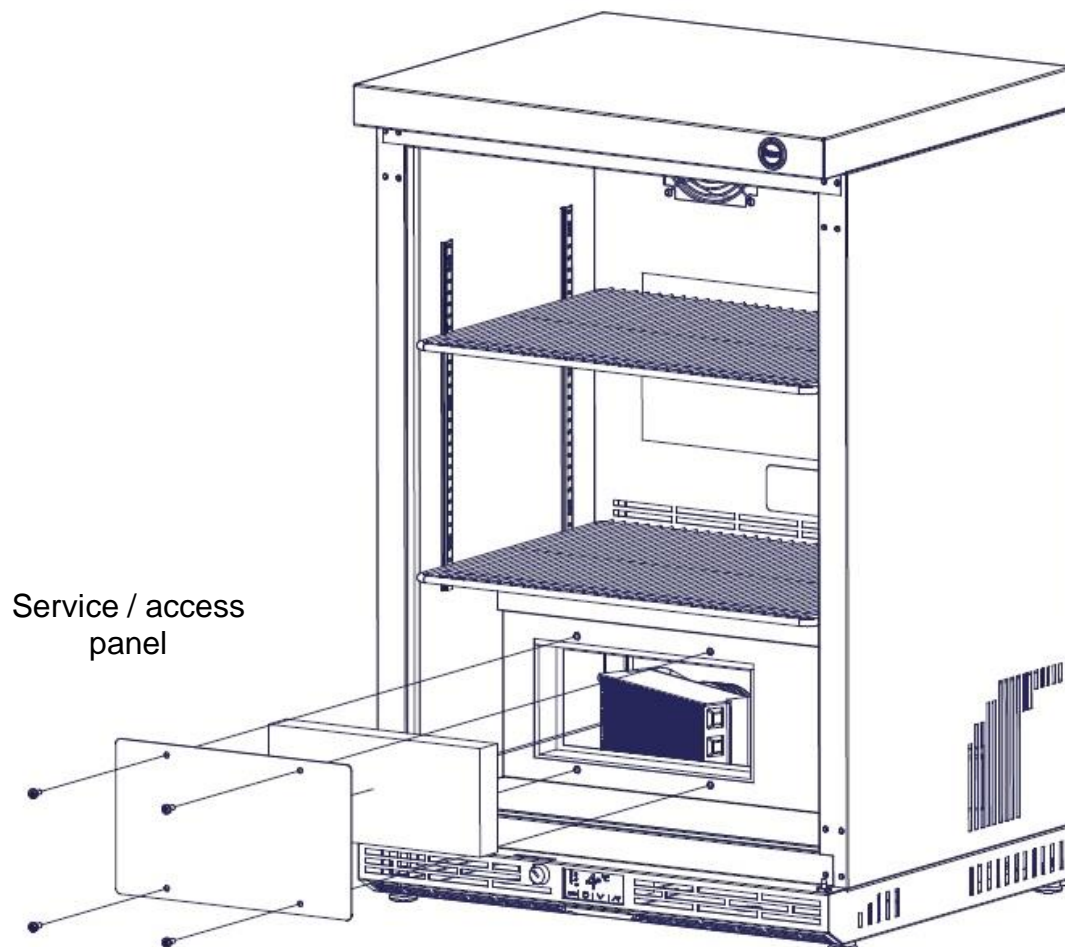

Other than regular cleaning the unit requires no maintenance by the end user. It is recommended that the unit is serviced by an IMC approved engineer at least once a year.

Details of IMC Service Contracts are available on application.

DO'S AND DON'TS

- Do** Install on a level surface.
- Do** Ensure plug is accessible with the unit installed.
- Do** Regularly clean the condenser and compressor.
- Do** Rotate stock of glasses.
- Don't** Sit or stand on the unit worktop.
- Don't** Load with boxed goods.
- Don't** Leave the doors open.
- Don't** Cover the shelves with any protective materials which may obstruct air circulation through them.
- Don't** Install unit in direct sunlight.
- Don't** Block the air inlet grilles.
- Don't** Store food in the unit.
- Don't** Place hot or warm goods in the unit.
- Don't** Use the unit outside.

ORDERING SPARE PARTS

In the event that spare parts or accessories need to be ordered, please always quote the SERIES AND SERIAL NUMBER of the machine. This is to be found inside the cabinet.

For installations outside the UK please contact your supplier.

For information on IMC spares and service support (if applicable), please call IMC on +44 (0)1978 661155. Alternatively, contact us via email or fax:

IMC Service Desk	Fax: +44 (0)1978 667766 E-mail: service@imco.co.uk
------------------	---

IMC Spares Desk	Fax: +44 (0)1978 667759 E-mail: spares@imco.co.uk
-----------------	---

END OF LIFE DISPOSAL

At the end of its useful life the unit must be disposed of correctly and safely, to meet the requirements of EU legislation regarding the recovery of ozone depleting substances. The unit must be sent to a specialist recovery, recycling and disposal site that is licensed for the disposal of refrigerated equipment. Please note that the insulation in the VR60 range does not contain any ozone depleting substances. The refrigerant used in the VR60 is R452a.

IMC can arrange removal of your redundant Glass Frosters, transfer to safe storage and disposal.

For more information contact IMC sales department.
Call +44 (0)1978 661155 Alternatively Email: sales@imco.co.uk

MATERIAL CONTENT

The VR60 units may contain a combination of the following materials;

Metals	Stainless Steel, Mild Steel (inc. Nickel Plated, Chrome Plated & Zinc Plated), Aluminium and Copper
Plastics & Rubber	PVC, Nylon, Polypropylene, Polycarbonate, Polyester, Acetate, Neoprene Rubber and Silicone Rubber
Insulation	Polystyrene, Polyurethane Foam
Oils & Gases	Ester oil, Refrigerant R452a
Other	Glass, Magnesium Oxide, electronic components.

SPARES LIST DRAWING 1

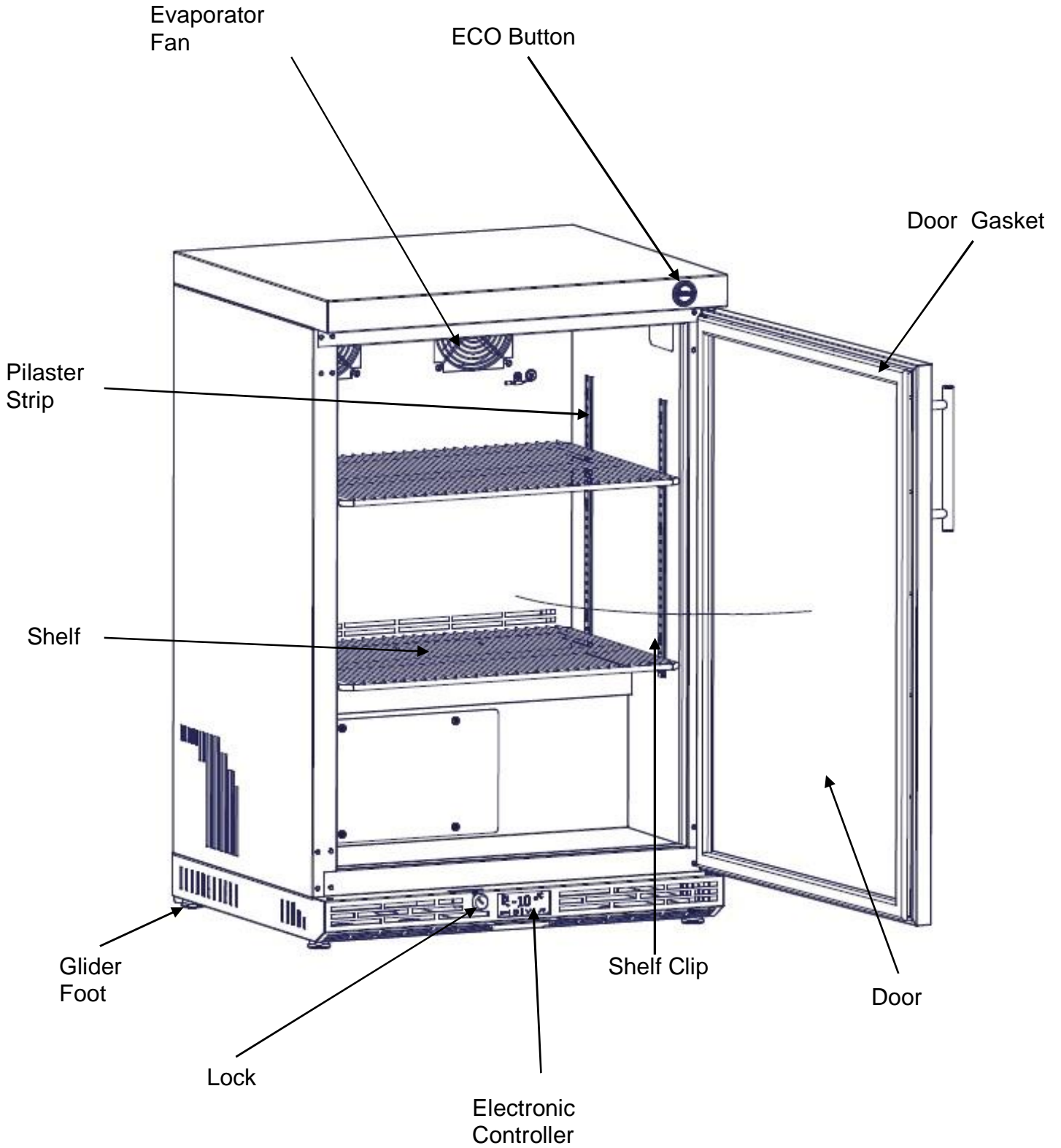

SPARES LIST DRAWING 2

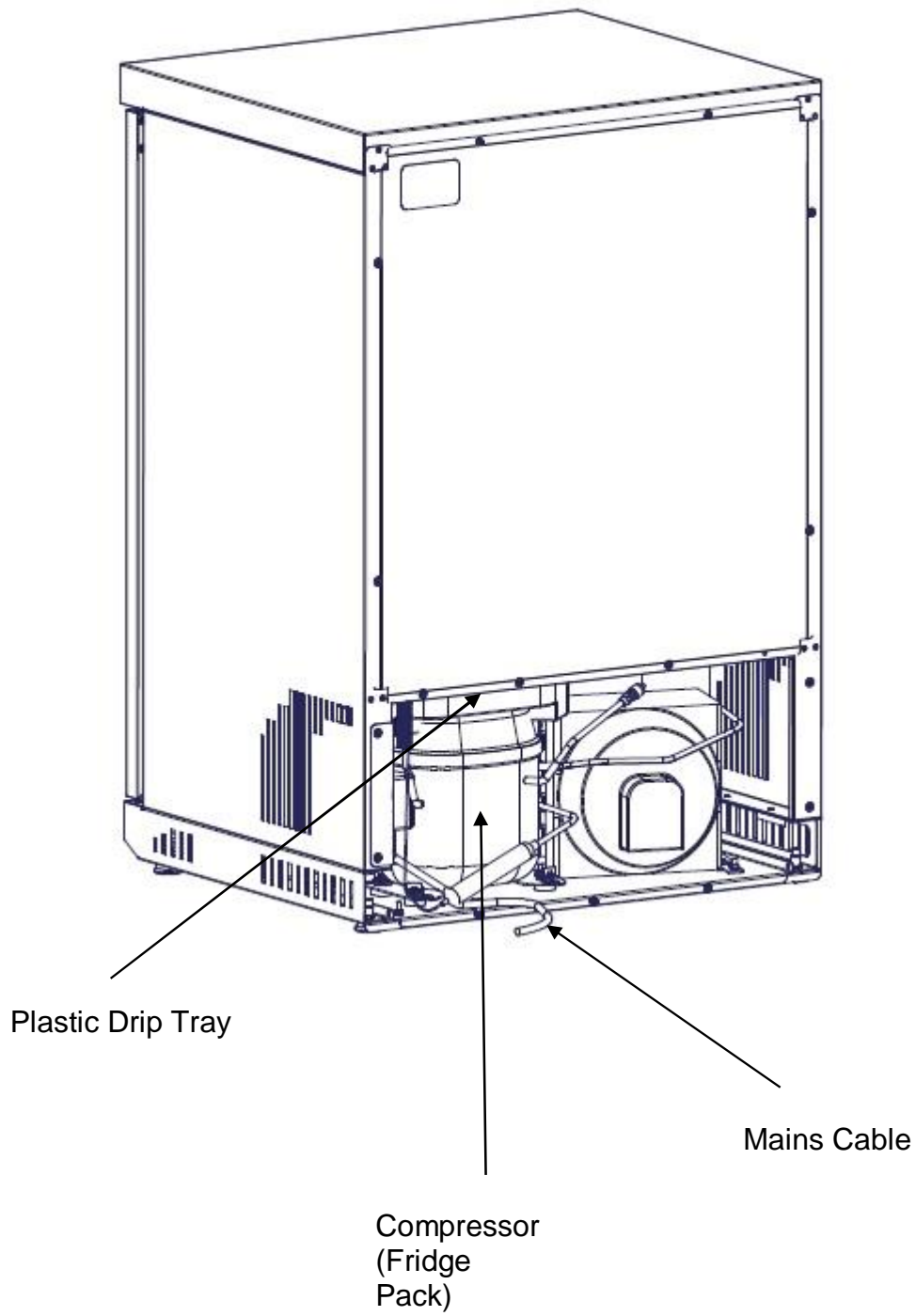

SPARES LIST

VR60 Glass Froster – Series 4	
Part No	Description
A11/278	Door Gasket (900)
A11/284	Door Gasket (800)
A12/073	Pilaster Strip
A12/091 Z1	Shelf
A12/082	Wine Shelf
S76/025	Perforated Shelf VR60
A12/094	Shelf Clip (4 per shelf)
A19/027	Glider Foot
A21/011	Lock, clip & keys
E76/221	Access panel
G30/562	Electronic Controller
G42/020	Plastic Drip Tray
G60/348 M1	Mains Cable
S49/066	Refrigeration Pack (900)
S49/071	Refrigeration Pack (800)
J09/049	Condenser/fan motor assembly
J09/026	Evaporator
J09/007	Service Drier
X08/057 (2mtr)	Capillary V60
G96/049	Evaporator Fan
S76/018	Door Handle (Short)
S76/023	Door Handle (Long)
S76/250	LED Assembly (white)
S76/253	LED Assembly (red)
S76/256	LED Assembly (blue)
S76/259	LED Assembly (green)

NOTES

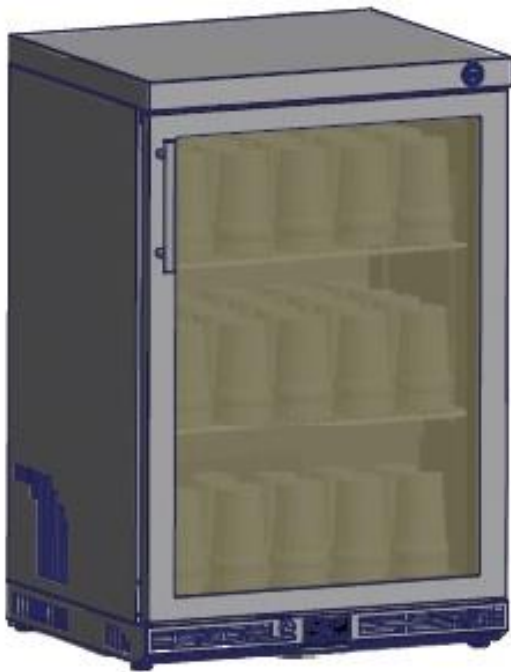

imc